



CAN-AM SPEEDWAY 602 CRATE SPRINT CAR RULES

(Updated: 2/2025)

Official Rules and Regulations DISCLAIMER: "The rules and/or regulations set forth herein are designed to provide for the orderly conduct of racing events and to establish minimum acceptable requirements for the orderly conduct of racing events within the 602 Crate Sprint Division at Can-Am Speedway.

These rules shall govern the condition of all events, and by participating in these events, all participants are deemed to have complied with these rules. **NO EXPRESSED OR IMPLIED WARRANTY OF SAFETY SHALL RESULT FROM PUBLICATION OF OR THE COMPLIANCE WITH THESE RULES AND/OR REGULATIONS.**

They are intended as a guide for the conduct of the sport and are in no way a guarantee against injury or death to a participant, spectator, or official. The Technical Inspector (s) or Director of Racing Operations shall be empowered to permit reasonable and appropriate deviation from any of these specifications herein or impose any further restrictions that in his / her opinion do not alter the minimum acceptable requirements. **NO EXPRESSED OR IMPLIED WARRANTY OF SAFETY SHALL RESULT FROM SUCH ALTERATION OF SPECIFICATIONS.** Any interpretation or deviation of these rules is left to the discretion of the Director of Racing Operations or his / her appointee. Their decision is final."

It is the responsibility of each competitor to read, understand and comply with these rules as written. They are neither foolproof nor exhaustive. They are intended to provide fair and competitive racing for all who participate in this division. The spirit and intent of these rules is the standard that will be used for competition at Can-Am Speedway.

Can-Am Speedway officials are authorized to decide if an equipment change or addition is an attempt to circumvent these rules or provide an unfair advantage. Officials can and will disqualify any entry in violation of the spirit and intent of these rules. Decisions will be based on

common sense, consistency, impartiality and fairness. If there is disagreement or dispute regarding the meaning, interpretation, or application of these rules, officials' decisions shall prevail. If these rules do not specifically say that you can add, change, or modify something, then you should consider that addition, change or modification illegal. Any questions about the legality of an addition or modification not covered by these rules must be answered by officials in writing, and their decision is final. Can-Am Speedway reserves the right to alter or amend these rules at any time in the interests of safety, cost control or fair competition. The safety of each race car and all equipment is the complete responsibility of the driver/owner, and the driver/owner acknowledges this responsibility by participating in any racing activity at Can-Am Speedway.

General Track Rules and Procedures

MANDATORY REGISTRATION

All Drivers **MUST** register in order to race.

COMPETITORS PITS

You or your crew may not enter a competitor's pit to complain or confront him or her. This offense will result in a fine, race day points and possible suspension as the officials see fit.

ALCOHOL AND DRUG POLICY

Drinking alcohol or taking any illicit drugs including marijuana in the pits is not permitted during any race event or practice. The driver is personally responsible for anyone associated with their car. If you or anyone associated with your car is found to have been drinking alcohol or taking any illicit drugs including marijuana you and your team will be escorted off of the premises including suspension as Officials see fit. The suspension will include car, driver and crew.

MANDATORY DRIVERS MEETING

A mandatory driver meeting takes place at each race event. Check the weekly schedule for time.

EXITING CAR ON TRACK

The driver shall not exit his or her car on the racing surface or unless there is a fire or injury or an official permit. Failure to follow this rule can result in a fine and or suspension.

HOW QUALIFICATION WORKS

Heat races determine if you qualify for the feature.

SCALES

You will be told on the 1-way radio how many cars scale after each race.

POINTS

Points for Features are awarded as per the 60-point system in the DIRTcar rulebook.

INDEX

- 0.0** Scoring
- 1.0** Can-Am Speedway Crate Sprint Car Official Car Specifications
- 2.0** Oil Pan/Pump/Pick-Up
- 3.0** Carburetor
- 4.0** Air Filter
- 5.0** Carburetor Space/Fuel Log
- 6.0** Fuel Pump/Adapter
- 7.0** Timing Chain/Gears
- 8.0** Headers
- 9.0** Front Cover Gaskets
- 10.0** Intake Gaskets
- 11.0** Rear Cam Seal
- 12.0** Cam Spud
- 13.0** Rear Counter Weight
- 14.0** Yoke and Bolts
- 15.0** U-Joint
- 16.0** Weight
- 17.0** Shocks
- 18.0** Rear End Gear Rule
- 19.0** Torsion Stop Retainers
- 20.0** Brakes
- 21.0** Chassis
- 22.0** Fuel Tank
- 23.0** Wheels
- 24.0** Carbon Fiber
- 25.0** Mufflers
- 26.0** Driveline System
- 27.0** Wings
- 28.0** Front (Wing; Axle; Bumper) Locations
- 29.0** Bumpers
- 30.0** Front Axle
- 31.0** Nerf
- 32.0** Protective Rock Screen
- 33.0** Floor Pan
- 34.0** Tires
- 35.0** Fuel

- 36.0** Numbers
- 37.0** Car's Equipment
- 38.0** Roll Bar Padding
- 39.0** Driver Seat
- 40.0** Seatbelts
- 41.0** Driver's Equipment
- 42.0** Cockpit Adjustments
- 43.0** In-Car Communication
- 44.0** Technical Inspection
- 45.0** Technology
- 46.0** Engine Repairs
- 47.0** Approved Can-Am Speedway Crate Engine Builders
- 48.0** Digital Media

0.0 Scoring

- 0.1 Timing and Scoring will be electronic via transponders (A,M.B. model TranX260) or Flex Transponders with human backup.
 - 0.1.1 Transponders are required. Transponders may be rented for \$15 per night.
 - 0.1.2 Rental units must be returned before pay will be released.
 - 0.1.3 Drivers who have their own unit must leave the unit code with the registrar for scoring purposes.
 - 0.1.4 Transponders must be mounted behind the frame diagonal located behind the front torque tubes and ahead of the front axle as indicated in the drawing below.
 - 0.1.5 The transponder must be located as close to the bottom frame rail as possible.
 - 0.1.6 Cars with Transponders found in locations other than that indicated above during post race inspection will be penalized two (2) positions.

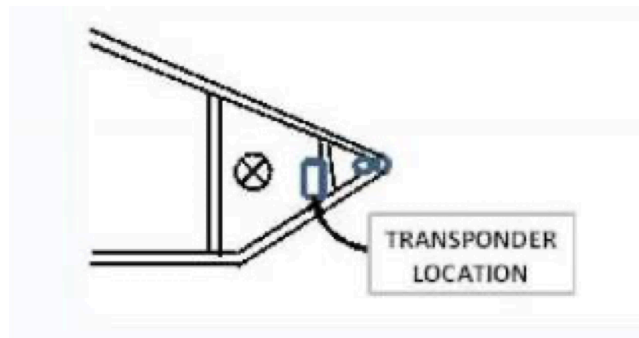

1.0 602 Can-Am Speedway Crate Sprint Car Official Car Specifications

Official Car Specifications GM Circle Track Crate Engine Part # 88958602/#19258602

- 1.1 Must remain stock.
- 1.2 Donath Motor Worx, Leitch Performance Engines, Lafrance Performance, Klotz Engine Machine Shop, and DSE,II be the only authorized engine conversion facilities.
- 1.3 All 602 Crate Engine conversions must be completed by Donath Motor Worx, Klotz Engine Machine Shop, Leitch Performance Engines, Lafrance Performance or DSE and will be sealed upon completion with Action Sprint Tour seals.
- 1.4 Any tampering with engines or engine seals will result in a (1) one-year suspension, a monetary fine may also be included.
- 1.5 At the discretion of the track engines may be removed and subject to further inspection.

- 1.6 If at any time tech is refused on the engine the driver and car will be suspended for a minimum of 2 racing events.
- 1.7 Stock HEI Ignition. Welding of mechanical advance will be allowed.
- 1.8 Vacuum advance lockout devices such as Proform 67022C will be allowed. All other devices require prior approval from the Technical Director.
- 1.9 The use of anti-spill valves on the carburetor vent tubes and valve cover vent tubes is MANDATORY in the interest of preventing fires during a roll over.
- 1.10 Valve Spring Shims are NOT allowed

2.0 Oil Pan/Pump/Pick-Up

- 2.1 Oil Pan Part # CP106LTRB (Champ Pans)-Mandatory
- 2.2 Oil Pump Part # M55 (Melling Oil Pump)-Suggested
- 2.3 Oil Pump Pick Up Part # 20-030 (Canton)-Suggested

3.0 Carburetor

- 3.1 Holley Carburetor Part # 0-80535-1 MUST REMAIN BOX STOCK-Mandatory
- 3.2 Jets and power valves may be changed.
- 3.3 Carburetor must be mounted parallel to the intake.
- 3.4 Track Officials reserve the right to exchange any competitor's carburetor at any time.
- 3.5 No air induction inserts or other devices to direct air to intake.

4.0 Air Filter

- 4.1 ONE round type air filter element maintaining a minimum of 4 inches and a maximum of 14 inches in diameter will be permitted.
- 4.2 K&N style filters will be allowed.
- 4.3 No special air cleaner top or bottoms that direct air into the carburetor.
- 4.4 No special air cleaner top or bottoms that direct air into the carburetor).
- 4.5 All air shall be filtered through the filter element.
- 4.6 No carburetor inserts to direct air into the carburetor.
- 4.7 No air boxes, hoses, or any device that directs air into the air cleaner.
- 4.8 No ram air.
- 4.9 The car must be equipped with an air filter

5.0 Carburetor Space/Fuel Log

- 5.1 Spacer Part # 6006 (Mr. Gasket)-Mandatory
- 5.2 Fuel Log Part # 26156 (All Star)-Suggested

6.0 Fuel Pump/Adapter

- 6.1 Fuel Pump Part # 9351 (Pro/Cam)-Suggested.
- 6.2 Fuel Pump Adapter Part # 308-10100 (Sweet Mfg Inc.)-Mandatory.
- 6.3 Fuel Pump location must be in the driver's cockpit.

7.0 Timing Chain/Gears

- 7.1 Timing Chain Part # 9-3100 (Cloyes)-Suggested.
- 7.2 Upgrade of Timing Chain is strongly recommended. Cost is \$120.00.

8.0 Headers

- 8.1 Header Part # 1052LV (Schoenfeld) or Motorstate PN #SCH1012LV (Schoenfeld).
- 8.2 Headers inside the surface must remain stock. Outside of headers may be coated/painted/etc.

9.0 Front Cover Gaskets

- 9.1 Front Cover Gasket Part # 87240 (Allstar)-Suggested

10.0 Intake Gaskets

- 10.1 Intake Gasket Part # MS16167 (Victor)-Suggested

11.0 Rear Cam Seal

- 11.1 Rear Cam Seal Part # 90085 (Allstar)-Suggested

12.0 Cam Spud

- 12.1 Cam Spud Part # 934-0005 (ARP)-Suggested

13.0 Rear Counter Weight

- 13.1 Rear Counter Weight Part # BER 372-NC-EXT (BERT)-Suggested

14.0 Yoke and Bolts

- 14.1 Yoke Part # WIN 65856 (Winters)-Suggested

15.0 U-Joint

- 15.1 U-Joint Part # Aftermarket #15

16.0 Weight

- 16.1 Minimum 1600 lbs. weight (with driver; no fuel added) after race.
- 16.2 Zero tolerance.
- 16.3 Tubing and nerf bars must be hollow.
- 16.4 Cars not meeting minimum weight will be disqualified for that race, last and start scratch in any further race that evening after meeting minimum weight.
- 16.5 **No Titanium** parts allowed except in rear ends.
- 16.6 Any Bolted-on Weight must be painted white, securely mounted and approved by tech inspectors.

17.0 Shocks

- 17.1 Twin Tube Shocks only.
- 17.2 No Gas Shocks will be allowed.
- 17.3 Non-Cockpit Adjustable Shocks allowed.

18.0 Rear End Gear Rule

- 18.1 515 Maximum Rear End Gear Ratio

19.0 Torsion Stop Retainers

- 19.1 Torsion stop retainers will be mandatory on all four corners. The retainer may be of the rodtype with a securing cap or insert with an expanding mandrel and/or any other approved torsion stop retainer design. Torsion stop retainers must be installed and used in accordance with the manufacturer's instructions.
 - The following torsion bar retainers have been approved for competition: Moose Block 1200 Retainer Kit
 - All Star Performance All Star 10730 Retainer
 - Maring Safety Retainer
 - Butlerbuilt Mandrel
 - KKR grove and clip
 - Kaeding Clip DMI – T-REX (Torsion Restraint Express System) Schroeder Part number "BARS" (for Schroeder bars with relief in ends) Schroeder Part Number: "RWLAR" (Wedge Lock)
 - The approved Torsion Arm Stop may be revised from time-to-time with additional approvals and/or other changes to the approved list.

20.0 Brakes

- 20.1 Steel or aluminum rotors only

21.0 Chassis

- 21.1 Any sprint chassis is allowed.
- 21.2 The roll cage must be of a four-post design.
- 21.3 No dirt champ cars.
- 21.4 No elliptical tubing used on or as part of the main frame structure.
- 21.5 No Chassis/suspension cockpit-adjustable devices (excluding top wing slider) are allowed.
- 21.6 12 Volt dry cell battery only. Must be mounted to the chassis.

22.0 Fuel Tank

- 22.1 Fuel tank must have bladder or can use Fuel Safe Enduro Cell.
- 22.1.1 Fuel Safe Enduro Cell will not be allowed for 2021 and beyond.
- 22.2 Fuel tanks must be securely fastened.
- 22.3 Any means of mounting the tank must meet the approval of the officials.
- 22.4 Tank size used for qualifying must remain for all events.

23.0 Wheels

- 23.1 No dual wheels are allowed.
- 23.2 No carbon fiber wheels.
- 23.3 Maximum allowed width of 18 inches for right rear wheel.
- 23.4 Maximum allowed width of 15 inches for left rear wheel.
- 23.5 Mud covers must have a minimum of 5 steel Dzus buttons or a minimum of 3 steel bolts minimum 5/16" in diameter.
- 23.6 Mechanical Bleeders WILL be allowed.

24.0 Carbon Fiber

- 24.1 No carbon fiber parts allowed in the suspension or drive line.

25.0 Mufflers

- 25.1 Although MUFFLERS not required, use of a Schoenfeld Muffler PN: #112535 is recommended.

26.0 Driveline System

- 26.1 All driveline systems must be properly installed, reinforced and/or covered. A steel driveline hoop or restraint is MANDATORY. A Torque Tube Tether and U-Joint scatter shield is Highly Recommended.
- 26.2 Steel Drive Shaft Only.

27.0 Wings

(Top)

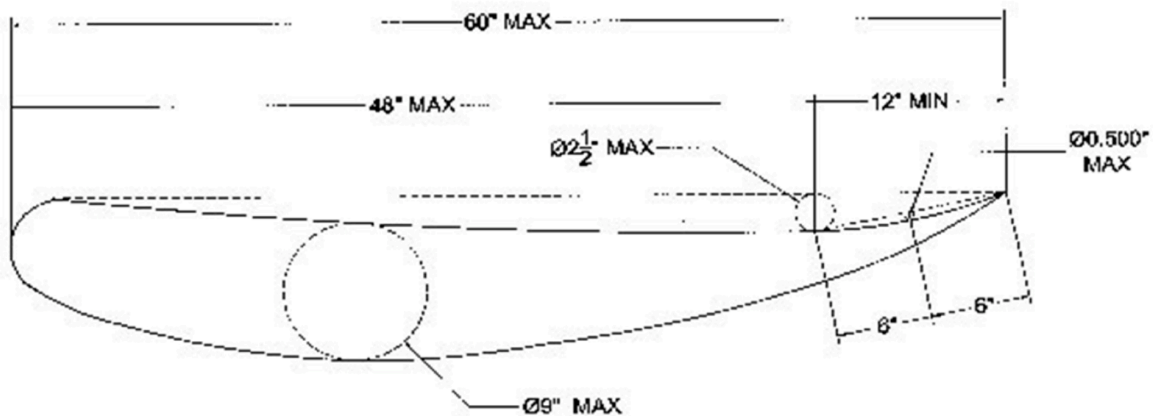

- 27.1 Maximum top wing size of 25 square feet with 30-inch side panels. Maximum center foil width 60 inches covered with aluminum. Side boards must be mounted at 90 degrees to the center foil. The deepest point allowed in the top surface of the wing will be 2-1/2 inches, measured from top front of wing to the rear edge. The 12-inch section located at the rear of the Center Foil must not have the belly/curl arc out of proportion with the rest of the Center Foil. The belly/curl arc must span the entire length of the Center Foil and appear to be a gradual arc with the deepest point no further back than 48 inches from the leading edge. As measured on a 12-inch straight edge, the belly at 6 inches from the rear of the Foil may not be deeper than 1/2 inch. Top surface of the wing measuring crosswise must be flat. Center foil must be one piece. No split wings or bi-wings. No vent holes. Top wings must not extend beyond the outside of rear tires. Core thickness not to exceed 9 inches.
- 27.2 Top wing sideboards maximum size, 72 inches long and 30 inches tall. Panels must be of one-piece construction. Panels must be fabricated flat so as to have no turnouts or flaps exceeding 1.25 inches including reinforcement (reinforcement not to exceed 1.25 inches).

- 27.3 NO turn-up (wicker bill) on 90-degree angle allowed at rear of center foil on dished wings. Flat top wings may utilize a 1" turn-up (wicker bill) at a 90-degree angle at the back edge of the top wing.
- 27.4 Two stationary rudders will be allowed to run under the entire length of the underneath portion of the top wing. Nowhere shall the rudder exceed 3 inches in height.
- 27.5 No car will be allowed to compete without a top wing.

(Front)

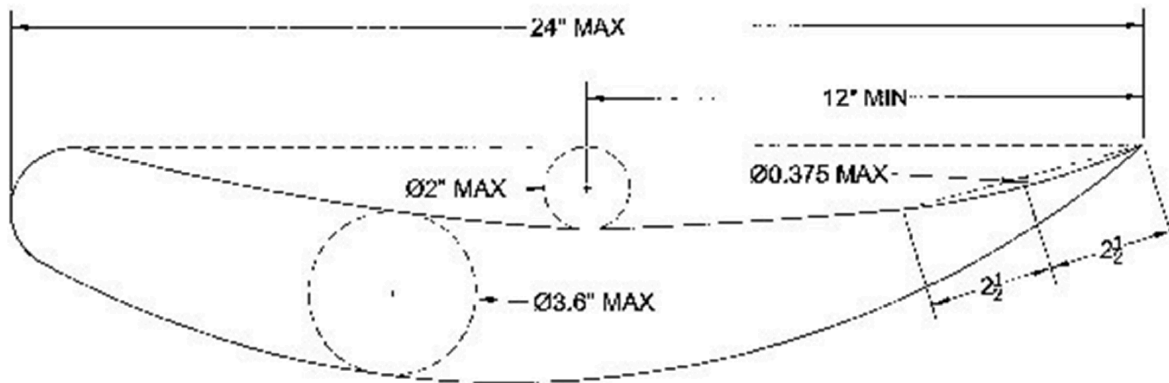

- 27.6 Maximum front wing size to be 6 square feet total with a maximum width of 36 inches and 12- inch side panels. The belly/curl arc must span the entire length of the front foil and appear to be a gradual arc with the deepest point, no further back than 12 inches from the leading edge. The belly/curl arc must start at the front foil's leading edge and shall not exceed a depth of 2 inches. The 5" section located at the rear of the front foil must not have a bell/curl arc that is out of proportion with the rest of the front foil. As measured on a 5-inch straight edge, the belly at 2 1/2 inches from the rear of the foil may not be deeper than 3/8 inch. (This 3/8-inch measurement ensures that the belly/curl arc is gradual). Top surface from side to side must remain flat. Core thickness not to exceed 3.5 inches.
- 27.7 Front wing side boards maximum size, 12 inches tall and 26 inches long with no more than one-inch overhang from the center foil front edge to the side board front edge.
- 27.8 The Front Wing must not extend beyond the outside of the front tires.
- 27.9 Sideboards may have front, back, top, and bottom turnouts of no more than 1 inch.
- 27.10 One-inch maximum turn-up (wicker bill) allowed on any front wing.
- 27.11 No rudders on Front Wings.
- 27.12 No moving parts allowed on or in foil structure.

- 27.13 Front wing may not be cockpit or driver adjustable while the car is stationary or in motion. 27.14 Cars must place track issued contingency decals in the way that track lays out. Map to follow.
- 27.15 Wings must be fabricated of metal alloys only. NO fiberglass, carbon fiber, or other similar material may be used.
- 27.16 No body pieces to extend beyond or underneath the front torsion tube except hood. No wedges or foils underneath the race car. No pieces may be added to the frame so as to resemble, imitate or be specifically designed to deflect, trap or form a wind break of any nature, except those used to cool/protect the motor & braking system.
- 27.17 Sunshields cannot restrict vision.
- 27.18 Cockpit adjustable front-to-rear (hydraulic) sliders are allowed on Top Wing.
- 27.19 No vent holes or louvers are allowed on any wing (or sideboard) surface.
- 27.20 Wing sideboards must be mounted at 90 degrees to the center foil.

28.0 Front (Wing; Axle; Bumper) Locations

- 28.1 Leading edge of Front Wing, Front Axle, and Front Bumper in relation to location of Torsion Tubes must be maintained.
- 28.2 The leading edge of the front wing cannot be further than 20 inches forward of the leading edge of the front axle.
- 28.3 The distance from the leading edge of the front bumper to the leading edge of the front torsion tube is a maximum of 8".
- 28.4 The maximum distance from the leading edge of the front bumper to the leading edge of the front axle is 23 1/2 inches.
- 28.5 The Front Wing leading edge must remain at least 1 inch behind the front edge of the front bumper.

29.0 Bumpers

- 29.1 All rear bumpers must be steel.
- 29.2 Diameter must be a minimum of one inch. Minimum .065 thickness and must be bolted in place (no pins, cotter keys, or pop rivets).
- 29.3 Maximum distance from the leading edge of the front bumper to the leading edge of the front torsion tube is a maximum of 8".
- 29.4 The maximum distance from the leading edge of the front bumper to the leading edge of the front axle is 23 1/2 inches.

30.0 Front Axle

- 30.1 Steel only. Minimum sizes: 2 inches by .156, 2- 1/4 inches by .120, 2 3/8 inches by .095.

31.0 Nerf

- 31.1 Steel only. Nerf bars must be bolted in place (no pins, cotter keys, or pop rivets).

32.0 Protective Rock Screen

- 32.1 A protective rock screen must be installed in front of the driver with no larger than 2" x 2" square openings.

33.0 Floor Pan

- 33.1 Steel or aluminum only.

34.0 Tires

- 34.1 Right Rear Hoosier D25, HTC-Medium 1
- 34.2 Left Rear tires 31169 92/15-RD12, 31189 94/15-RD12, 31209 96/15-RD12
- 34.3 Front Tires 31131 D12 85/80 must be used for all Can-Am Speedway sprint events.
- 34.4 Left Front is the only tire you can run flat.
- 34.5 Use of tire softener prohibited.

35.0 Fuel

- 35.1 Methanol or ethanol fuel only
- 35.2 Top lube or fuel-coloring agents are discouraged but the only additives allowed; performance enhancing fuel additives are not allowed.
- 35.3 Suspected fuel will be tested at the team's expense and money will be withheld until results are returned to Can-Am Speedway.
- 35.4 If fuel found to contain performance-enhancing additives, disqualification will result in forfeiture of all monies won.

36.0 Numbers

- 36.1 Numbers must be visible and neat in appearance.
- 36.2 Numbers must be on both the left and right side of the tail, as well as the side panels and center foil of the top wing.
- 36.3 Numbers must be at least 16 inches high, and letters at least 12 inches high, on the top wing.

- 36.4 In the event of duplicate numbers, teams may be asked to temporarily add a unique letter to their number in all locations on the car.

37.0 Car's Equipment

- 37.1 Use a securely fastened steering wheel with a quick disconnect and removable steering wheel. 37.2 A tether is MANDATORY on the drag-link, attached to the frame.
- 37.3 Steel drag links, tie rods, and Heim Ends on steering are mandatory.
- 37.4 No aluminum roll cages, front axles, frames, rear bumpers or nerf bars.
- 37.5 All roll cages must be higher than the driver's helmet.
- 37.6 Opening on the left-hand side of the cockpit must be a minimum of 14 inches. 37.7 Opening on the right-hand side of the cockpit must be a minimum of 12 inches.
- 37.8 Side body panel designs and/or concave surfaces that, in the sole discretion of Brockville Speedway officials, are intended to trap, alter and/or direct airflow for the purpose of gaining aerodynamic performance advantage will not be permitted.
- 37.9 No body pieces are to extend beyond or underneath the race car. A minimum wheelbase of 83 inches or a maximum wheelbase of 90 inches is allowed.
- 37.10 No pop rivets or cotter keys to be used to fasten wings, bumpers or nerf bars to race car.
- 37.11 No drilled or hollowed bolts in the car's steering components.
- 37.12 The sprint car cannot be raced without a hood.
- 37.13 If a rear bumper is lost during a race, the car may continue until the car is stopped.
 - 37.13.1 If a red flag situation occurs, the rear bumper must be replaced in the allotted time before it can be restarted.
- 37.14 All cars Components must be compatible for competition in the 360 Sprint class. No unique Crate Sprint only components
- 37.15 Metal fasteners are strongly suggested.
- 37.16 A right-hand side head restraint system is recommended; it is also recommended for the left-hand side. In some cases, head nets may not be required if the seat restraint system is approved by track officials.
- 37.17 Knee pads or other devices to keep the knees from banging around on objects and causing injuries are encouraged.
- 37.18 Shoulder/helmet restraints are also encouraged. 37.19 – Carbon Fibre Body Panels are NOT allowed

38.0 Roll Bar Padding

- 38.1 Roll cage MUST have protective padding.

- 38.2 Roll bar padding MUST cover the upper part of the roll cage on both sides, and behind the driver's head.
- 38.3 Roll bar padding must also be placed on any parts near the driver's head.
- 38.4 A type of Styrofoam or fiberglass insulation of one-inch thick with an upholstery-type covering is suggested.
- 38.5 If arm-a-fax or foam rubber is used, it should be considerably thicker.
- 38.6 Safety/ Support bars are mandatory in 2020. All cars must have them. See Drawing below

Support Bar

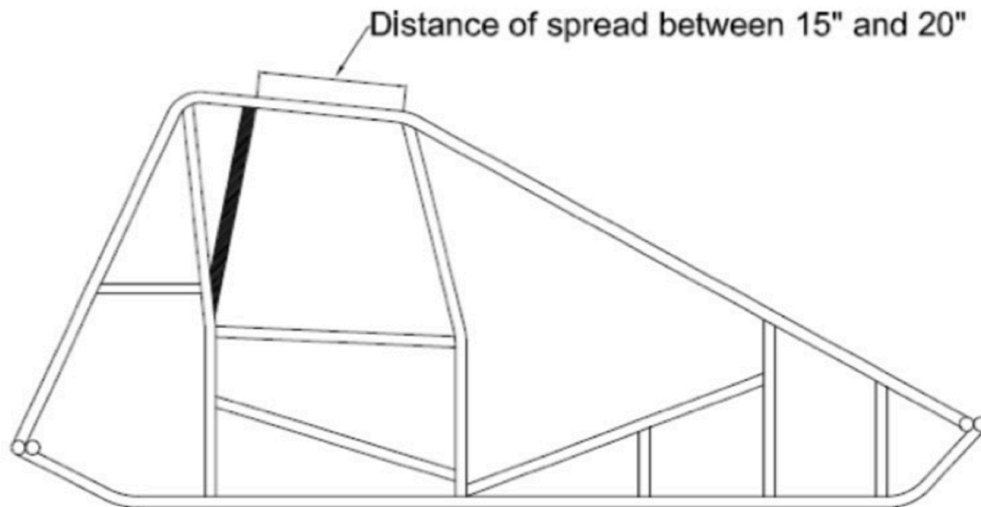

39.0 Driver Seat

- 39.1 Driver's seat is required and must be securely fastened with a minimum of four bolts.
- 39.2 A high back style seat is mandatory.
- 39.3 A padded headrest is recommended.
- 39.4 A fuel/fume deflector should be wider than the driver seat and extend from the floor pan underneath the seat to turn-up behind the seat.
- 39.5 Safety harness and lap belts MUST be routed through the belt holes in the side and back of the seat.

40.0 Seatbelts

- 40.1 Seatbelts should have the five or six-point configuration of attachment to the frame or roll cage.
- 40.2 The shoulder belts should be attached behind the seat to the frame or roll cage parallel or higher than the driver's shoulders.
- 40.3 Belts must be no more than TWO YEARS old.

41.0 Driver's Equipment

- 41.1 Drivers are required to wear a proper fitting, SA 2015 or newer SNELL approved full face Helmet.
- 41.2 A Flame-Retardant driver suit, Gloves, socks, underwear (unless a 3-layer suit is utilized), and shoes are required.
- 41.3 A head sock is also suggested. Helmets; Driver Suits; fastened seat belts, shoulder harness, anti- sub strap, and arm restraints are to be used anytime the car is started
- 41.4 A head and neck support or restraint system is mandatory. (Use of HANS Device is highly recommended)
- 41.5 Safety belts and arm restraints must be no more than TWO YEARS old and contain unaltered 41.5SFI safety labels. Arm restraints built into the driver's suit must be in good repair and subject to approval of the technical director.

42.0 Cockpit Adjustments

- 42.1 Other than wing sliders, NO cockpit adjustable devices are allowed.
- 41.2 This includes, but is not limited to brake bias, shocks, suspension and fuel.
- 42.3 No wiring will be allowed inside the cockpit.
- 42.4 All wiring to instruments must protrude from the engine compartment through the firewall and directly into the instrument.

43.0 In-Car Communication

- 43.1 No two-way radios are allowed
- 43.2 RACE RECEIVER One-way radios (ch; 454.000) are mandatory. 43.3 No Mobile Devices allowed in cars during competition.

44.0 Technical Inspection

- 44.1 Post Race Technical Inspection carried out within the confines of Tech will be completed under the following guideline: Cars to be inspected must proceed immediately to the Tech Inspection area after the race. No team members are allowed to touch or remove any part of the race car without receiving prior approval of the Head

Tech Official; Cars (with Driver) must enter the tech area as instructed by inspectors. Drivers must move their race car onto scales or be assisted by track officials only if needed; Access to Tech will be restricted to the car driver and two crew members. The team is responsible for preparing only the area(s) of the race car for inspection as requested by the HEAD TECH OFFICIAL in a timely manner.

- 44.2 Any participant (team) who refuses to allow tech officials to inspect their car at any time or follow inspection directions and procedures will be subject to the following: Immediate disqualification from the event. Loss of points and prize money for that event. Credited with a future win for handicapping purposes (if applicable).
- 44.3 Participants found to be illegal and disqualified during technical inspection shall be subject to the following: Disqualification from the event. Loss of points and prize money for that event.
- 44.4 A second infraction for deemed illegal or technical issues will result in the following; Disqualification from the event. Loss of points and prize money for that event. TOTAL LOSS OF ALL ACCUMULATED POINTS TO DATE.
- 44.5 All new cars must arrive at the track one hour prior to start time and report to the tech inspector. 44.6 If a car does not meet our rules it will not be able to compete. No exceptions.
- 44.7 All cars are subject to inspection by Can-Am Speedway officials at any time and in any manner determined by track officials. All decisions regarding the timing and manner of the inspections, as well as which cars will be inspected, are final.
- 44.8 Can-Am Speedway reserves the right to confiscate any illegal components at any time as deemed necessary.
- 44.9 Can-Am Speedway reserves the right to impound any car for any reason at any time.

45.0 Technology

- 45.1 No traction-controlled devices of any kind allowed.
- 45.2 This includes mechanical and electronic traction control devices.
- 45.3 No wheel speed sensors permitted.
- 45.4 No microprocessor-operated or controlled parts (such as fuel injections, fuel systems, etc.)
- 45.5 Cars may be asked to disconnect tachometers at the discretion of the technical committee.
- 45.6 No electronic tired bleeders allowed.

46.0 Engine Repairs

- 46.1 If any engine repairs are needed; all work must be authorized by the Can-Am Speedway tech director. A proper request must be submitted and approved prior to any commencement of work.
- 46.2 All replacement heads must be purchased through the speedway.
- 46.3 All existing seals will be removed and a new set will be installed to reflect the repair work and have associated
- 46.4 Head replacement work must be witnessed by a tech official whenever possible.

47.0 Approved Can-Am Speedway Crate Engine Builders

- Donath Motor Worx
 - 4878 Route 20, LaFayette, NY 13084
 - 315.677.8116 | donathmotorworx@yahoo.com
- DSE Performance Inc.
 - 265 Argyle St. N Caledonia, ON N3W 1K9 | www.dseperformance.com
 - Dale Stroud or Thatcher Krupp: 905.765.8880 | thatcher@dseperformance.com
- Klotz Auto Repair & Engine Machine Shop
 - 330 Dundas St. S. Cambridge, ON N1R 5S2 | www.klotzautorepair.ca
 - Mike or Mark Klotz: 519.620.4664 | klotzauto@bellnet.ca
- Lafrance Performance
 - 16397 Stormont/Dundas/Glengarry, Country Rd 2 Long Sault, ON
 - Yves Lafrance: 613.551.6212
- Leitch Performance Engines
 - 4080 North Service Road, Unit 21 Windsor, ON N8W 5X2 | www.leitchperformanceengines.com
 - Gary Leitch: 519.988.0037 | gary@leitchperformanceengines.com
- Workman Engine Machine
 - 1180 Stoney Point Road, Brighton, ON K0K 1H0 | www.workmanmachine.ca
 - Mike Workman: 613.475.0754 | sales@workmanmachine.ca

48.0 DIGITAL MEDIA

- 48.0 All participants (drivers, crews, and fans) are consenting to picture(s) and video(s) taken throughout events at Can-Am Speedway to be used in promotional materials.
- 48.1 All participants are encouraged to promote our sport in a positive manner (both in person and online).
 - 48.1.1 Participants are encouraged to utilize the 24-hour rule prior to placing names of the facility and/or other competitors on a digital media platform in a negative manner. Many times after 24-hours opportunities to resolve a problem increase when all parties have had a “cool down” period.